



Conveyor Belt Cleaning

By Steve Broadwell

Sales Manager

July 8, 2014

Many times, conveyor belt life is dramatically shortened by a failure to keep the belt clean. This is good for us in the belting business, but bad for the belt users. Just a little bit of time and attention can result in lower annual belting expenditures.

First, this article is not directed at food plants, where hygiene requirements are much higher. It is directed at users of lightweight conveyor belts used inside plants for unit loads, process conveying, and certain bulk applications.

We will start with the bulk applications. Companies making wood panels (particleboard, MDF, OSB, etc.) convey the wood chips or sawdust. Companies making nonwoven textile products such as auto insulation convey textile fibers. These type applications all have a big problem with material buildup inside the belt. The fine material gets underneath the belt path and compressed between the belt and the pulleys. Many times, the diameter of the pulleys is increased due to this, and the belt gets tighter and tighter. Eventually, the belt splice fails, or the belt simply stretches to the point where slippage starts to occur. Additionally, the pulley buildup can cause false crowns, making the belt mistrack and suffer edge damage.

The best solution to this problem is to prevent materials from getting underneath the belt. This is often easier said than done, though. Sometimes skirt boards can be added to the sides of the belt, but often this is not possible. In these cases, you really should clean the bottom of the belt frequently. Once per day, take compressed air and blow the material out of the system. This will only

take a few seconds, and you can greatly increase belt life.



Conveyor skirting added to the frame of the conveyor helps prevent material from getting under the belt

Another solution is to put a rotating brush (best) or a scraper against the pulley side of the belt. There is usually room to place this on the return side. Just be sure to angle any such device, so that materials are “ploughed” off the edge of the belt. Regardless of how you do it, you really need to keep materials from underneath the belt.

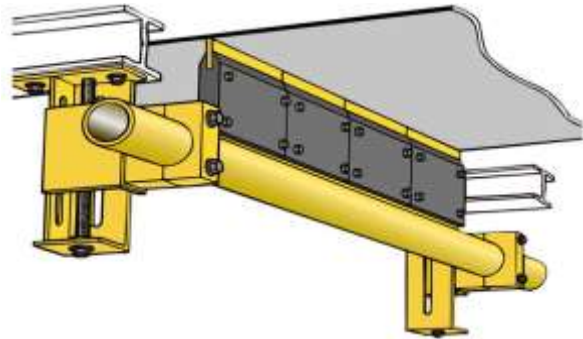

Fixed scraper on the pulley side of a belt will clean debris before the belt reaches the return roller

Many times, the top cover of a belt becomes dirty or stained. Often this does not hurt the physical performance of the belt, but can soil conveyed goods. It is a good idea to inspect belt covers periodically. If they are stained noticeably, clean them. The three most common belt cover materials are synthetic rubber, PVC, and polyurethane. All can be severely damaged by using the wrong cleaning agents, so care is required. The organic citrus-based cleaners are safe, and will usually do a good job. For extra tough stains, you may want to try denatured alcohol. Just wet a cloth with the cleaner and scrub the belt.

Be very careful about the use of strong solvents such as MEK, which will dissolve most cover

materials. If you are in doubt, contact your belt supplier, who should be able to furnish you a chemical resistance sheet for your belt.



A dirty belt, while still functional, can soil the products being conveyed and may possibly lead to other issues.

Remember, a little bit of preventative maintenance can save you a lot of money in the long run.

Steve Broadwell has worked with belting manufacturers for almost 30 years, and has a deep knowledge of lightweight conveyor belting. Contact him at either of our Southeastern US locations:

Bowman Hollis – North Carolina
2925 Old Steele Creek Road
Charlotte, NC 28208
PH: 888-269-2350

Bowman Hollis – Georgia
1606 Orchard Hill Road
LaGrange, GA 30240
800-822-6483